

# Telebelt® TB 130 Telescopic Belt Conveyor



- **130 ft Horizontal Reach**
- **Fully Hydraulic Feed Conveyor**
- **360° Continuous Rotation of Feeder and Main**
- **Max. Rated Output up to 360 yd<sup>3</sup>/hr (275m<sup>3</sup>/hr)**
- **Handle Concrete from 0" to 12" Slumps (0 to 305mm)**
- **Place Materials Sized from Sand to 4" (100mm) Rock**
- **Setup and Operate Under Low 15 ft 4 in (4.7m) Heights**

**Boom** Five section telescopic boom – base steel section and four aluminum sections for high strength and lightweight mobility. Simple to operate, one predetermined control lever extends and retracts all boom sections in a synchronized manner. At full extension, a 130 ft horizontal reach is achieved, making the net reach comparable to a 42 meter boom pump. Maintenance-free sealed roller bearings mean no time wasted greasing; and the quick telescoping feature and versatile 360° rotation enables immediate use once on-site, allowing for several pours in a day.

**Main Conveyor Belt** A continuous 18" (457mm) 2-ply nylon core vulcanized spliced belt – hot melt with no staples or mechanical splices – is on a series of highly durable pulleys. An infinitely variable belt speed control from 0 to 10 allows the operator to select the ideal output for the task . . . from a low 1 yard an hour up to a maximum rated 360 cubic yards an hour (275m<sup>3</sup>/hr). A tungsten carbide scraping plate at the discharge end helps scrape materials back into the trunk and down into the pour.

**Feeder Belt** A versatile 38 ft (11.6m) 2-section aluminum "active" hydraulic feed conveyor with 360° continuous rotation allows materials to be loaded from virtually any position desired. Feed the 18" (457mm) belt via mixer truck, dump truck, skid-steer loader or front-end loader. A sturdy integrated UHMW polyethylene feeder hopper can accommodate the toughest of mixes as well as aggregates from sand to 4" (100mm) rock – with no priming necessary.

**Boom Control and Operation** Main conveyor functions are controlled through a **Modular Boom Control (MBC)** system. Unlike a stacked valve arrangement this unique modular approach allows maintenance on a single valve without removing the entire valve assembly. This reduces labor and parts costs, yet improves overall machine control. All boom and belt functions are at the operator's

fingertips via the lightweight standard proportional radio remote control. This ergonomic design features main and feed conveyor rotation and elevation; main conveyor telescopic functions; main and feeder on/off and variable independent belt speed control. Additionally, the TB 130 comes with a standard "black and white" 90 ft (27m) cable remote for sites that do not permit the use of the radio remote. The unit is also equipped with an operator's control station from where all functions can be operated manually in emergency situations.

**Handling Concrete Mixes** Due to the unique style of conveying, keep mix designs matched exactly to customer specs. As admixtures are not needed to help place concrete, the TB 130 can convey harsh mixes from 0" to 12" (305mm) slumps without worry of inconsistency.

**Trunk or End Hose** Telebelt conveyor design allows for smooth, surge-free flow from the 15 ft (4.57m) trunk to reduce labor costs and make life easier on the hoseman. Both 8" (200mm) and 12" (305mm) tremies, which are steel cones at the tip end of the main conveyor, and 8" and 12" delivery trunks, and end hoses with chain binders to connect them, come as standard equipment. For larger volume pours and rock jobs, the 12" package is the ideal choice with a simple and quick interchangeable design.

**Power** Four (4) hydraulic circuits are driven by two full horsepower air shift rear PTOs from the Mack MR 688S 400 hp truck engine. A low rpm and only 175 hp (130kW) is needed to run the Telebelt at full capacity for reduced noise levels, less fuel consumption and lowered maintenance costs.

**Outriggers** Patent-pending telescopic outriggers allow quick and easy setup in congested areas, whether on solid or rough terrain. This helps to quickly complete pours from one convenient setup location and eliminate the need for all-wheel drive mixer trucks. Front and rear outriggers hydraulically telescope out and extend down. Activate the outrigger controls from behind the cab or from the touch pad controls mounted at the rear of the truck.

**Clean Out** For a quick and basically self-cleaning process, just run water into the feeder hopper and up the belt. A high pressure 2500 psi (173 bar) hydraulically-driven water system with a large capacity 170 gallon (644L) water tank greatly assist the process. And remember, with conveying, no additional concrete must be disposed of when finished with the job so you order only what you need . . . savings that add up daily.

**Additional Standard Features** Transfer chute, aluminum diamond deck work platforms, large side-mounted aluminum tool boxes, emergency stop button, high quality paint finish, operator manuals and ship-away kit are in addition to all the standard features mentioned above.

**Options** Rock hopper, front-end loader hopper, low profile hopper and custom paint schemes are optional. Consult factory for options not listed.



# Specifications TB 130 Belt Conveyor

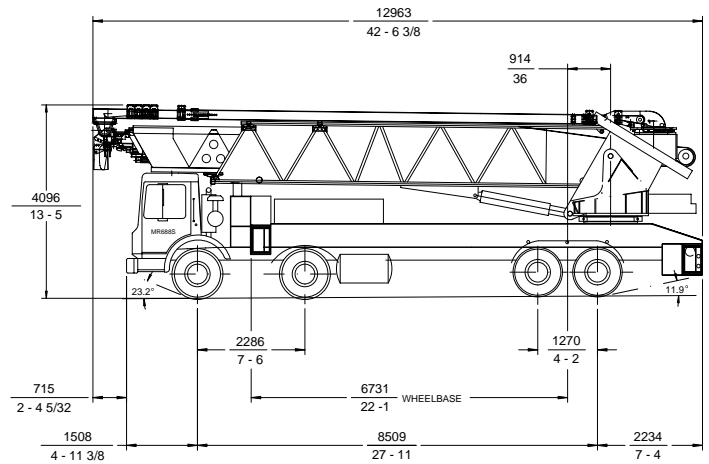
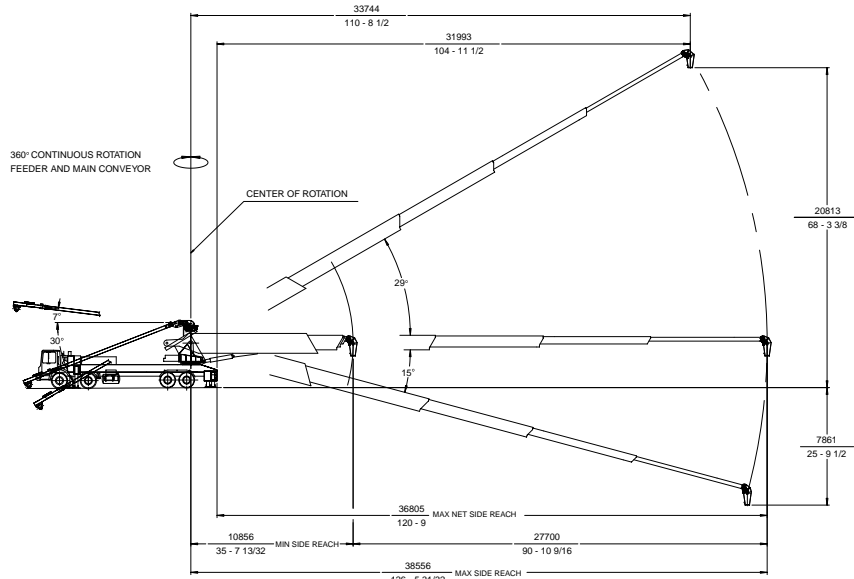
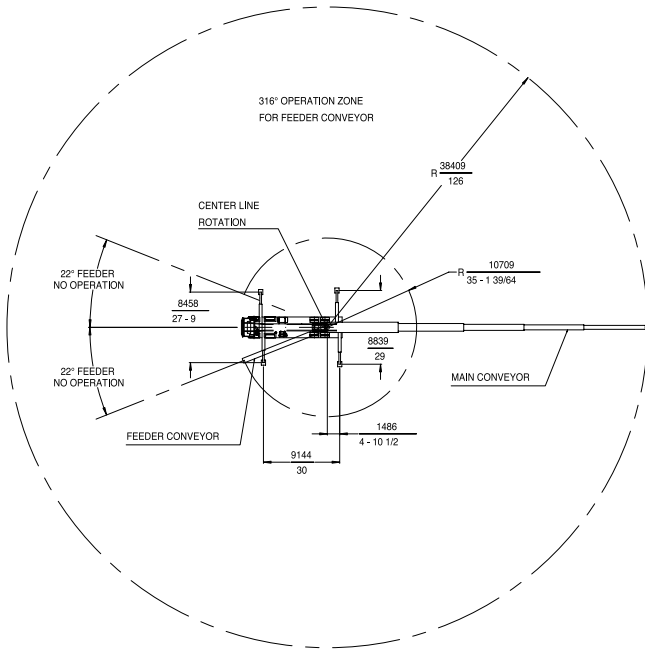

## TB 130 Belt Conveyor Specifications

Conveyor horizontal reach –		
Maximum at 0°	130'	(38.56m)
Maximum at 30°	109'8"	(33.41m)
Conveyor belt width	18"	(457mm)
Feed conveyor length	38'	(11.58m)
Feed conveyor belt width	18"	(457mm)
Trunk/end hose length	15'	(4.57m)
Discharge height –		
Maximum at 30°	68'3"	(20.81m)
Maximum at -15°	-40'9"	(-12.5m)
Rated capacity at 0°	6 yd <sup>3</sup> /min	(4.6m <sup>3</sup> /min)
main & feed conveyors	360 yd <sup>3</sup> /hr	(275m <sup>3</sup> /hr)
Rated capacity up to 20°	3.8 yd <sup>3</sup> /min	(2.9m <sup>3</sup> /min)
main & feed conveyors	230 yd <sup>3</sup> /hr	(175m <sup>3</sup> /hr)

Maximum theoretical values listed above.

### Outriggers

Net reach beyond outriggers –		
at 0 degrees	120'9"	(36.81m)
at 30 degrees	105'	(32.00m)

### Outrigger spread –

Front, telescopic out/down	27'9"	(8.46m)
Rear, telescopic out/down	29'	(8.84m)

### General Specifications

Water tank capacity	170 gal	(644L)
Hydraulic oil tank capacity with cooler	130 gal	(492L)

### Truck Specifications

#### Mack MR 688S

Weight	22,020 lbs	(9987kg)
Wheelbase	265"	(6731mm)
Cab height	104"	(2642mm)
Steering radius	45'6"	(13.87m)
Steering angle	38°	
Fuel tank capacity	110 gal	(416L)
Transmission	Mack T2090 9 Speed	

All specifications apply to units mounted on MACK MR688S.

### Transport Axle Weights - lbs. (kg)

Based on Model Mack MR688S

Steering	Tandem	Total
30,714 lbs (13,932kg)	40,893 lbs (18,549kg)	71,607 lbs (32,481kg)

Weights are approximate and include conveyor truck, full hydraulic oil, driver and some fuel. Dimensions vary with different truck makes, models and specifications.



**Putzmeister America**  
1733 90th Street  
Sturtevant  
Wisconsin 53177 USA

Telephone (262) 886-3200  
(800) 884-7210  
Facsimile (262) 884-6338  
www.putzmeister.com

Right to make technical amendments reserved.